

# HOTLINE

## 1/2009

**NEW at EWIKON**

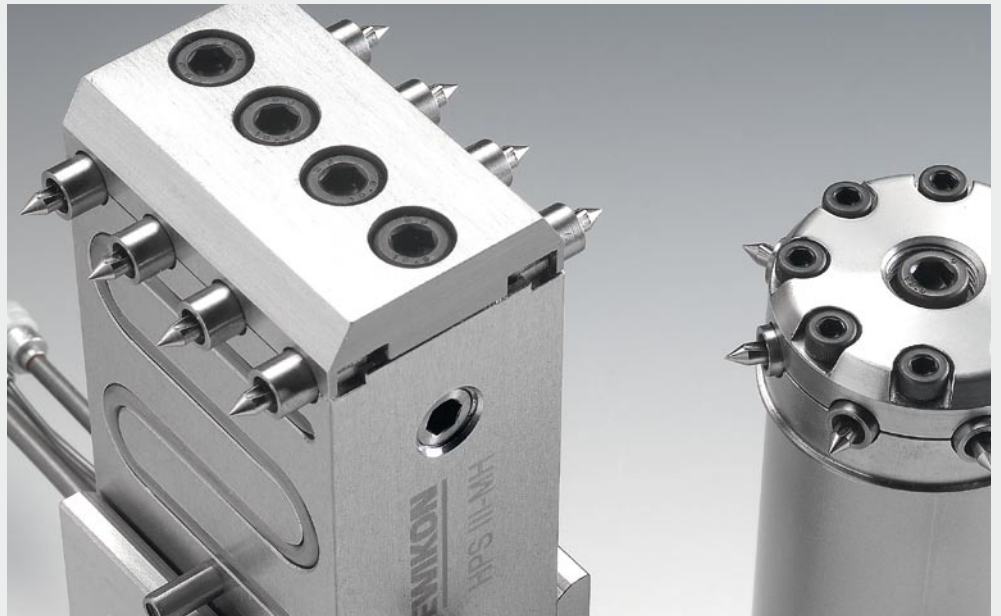

For medical and packaging applications:

### **HPS III-MH for direct side gating**

Pages 2-3

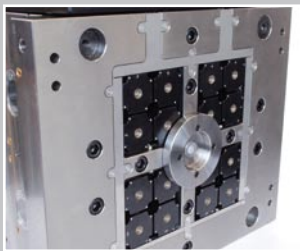

**Hotrunner systems for the medical industry**

Page 8

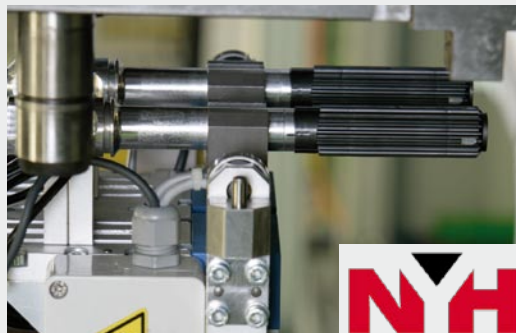

### **Steering column production:**

**Electric drive valve gate systems used by New-York Hamburger AG**

Pages 4-6



### **Multi-cavity hotrunner:**

**Two-component nozzle for silicon cartridges produced with spin stack mould**

Pages 6-7

**HOTLINE**  
**1/2009**

February 2009



## **L2X**

**New slim nozzle version**

Page 3

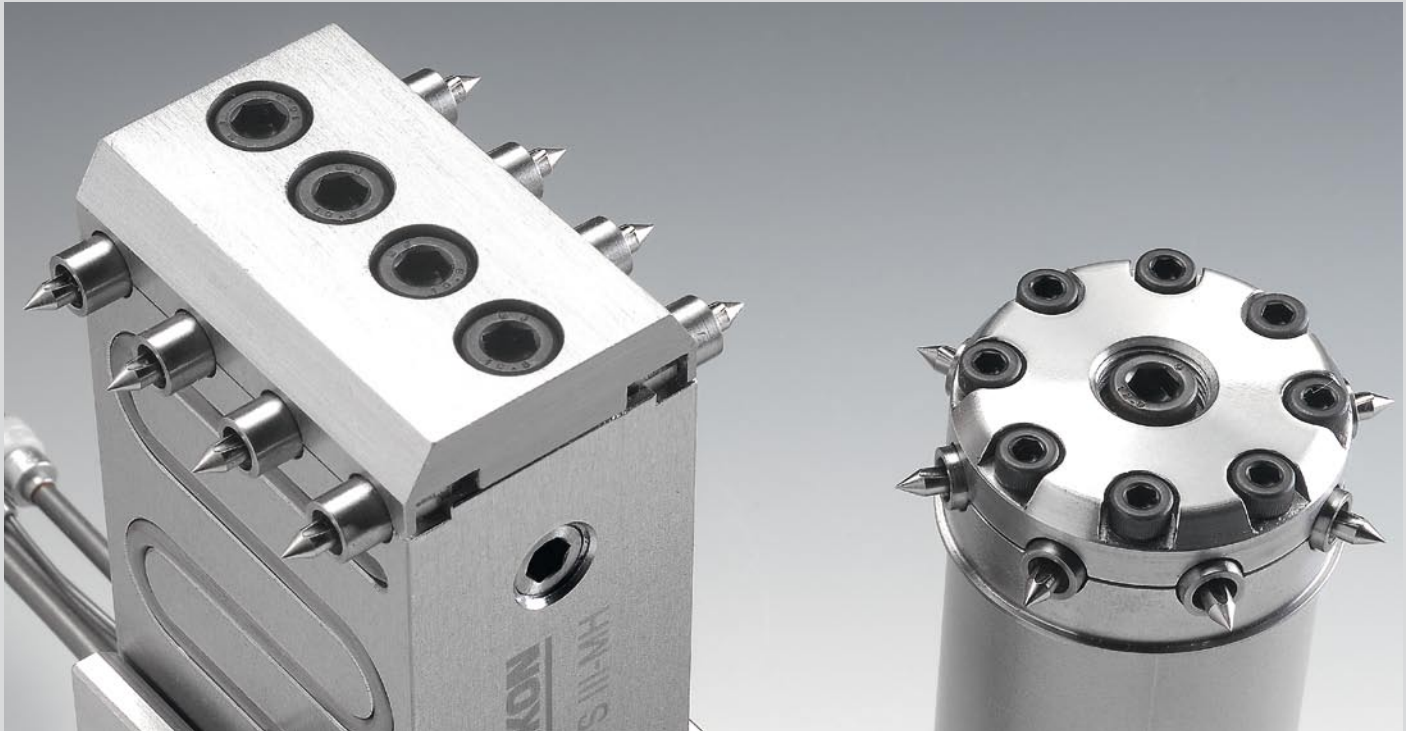

## The new solution for direct side gating with easy installation and maintenance

The new EWIKON HPS III-MH nozzle has been designed for use with standard mould inserts offering an incomparable maintainability as the tip inserts are exchangeable from the parting line without the need to dismantle the mould.

The new nozzle concept is ideally suited for applications where due to the article contour vertical gating is not possible.

Certainly the main field of application is the medical technology sector with a multitude of slim and often tubular or sleeve-shaped articles such as pipettes, syringes, syringe pistons or cuvettes which have to meet high quality requirements and are mass-produced in high-cavity, compact moulds.

But the HPS III-MH nozzle is also the ideal solution for the packaging industry, e. g. for the production of hinged closures. It uses a heat conductive tip insert to gate directly onto the part surface. This avoids cold slugs in the gate and guarantees a high quality gate vestige.

### Cost-efficient moulds, easy maintenance

A newly developed assembly system for the heated tip inserts allows for easy integration in a standard one-piece mould insert and therefore a cost-efficient mould

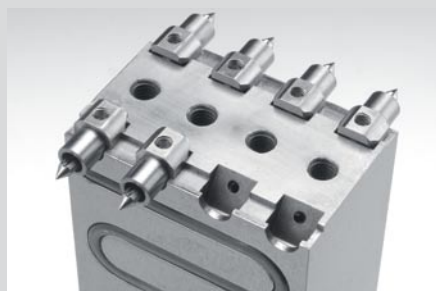

Easily accessible tip inserts for easy maintenance

design. The tip inserts are installed from the parting line of the mould in the last assembly step after the nozzle body and the manifold have been installed. Thus, if required they can be exchanged easily without having to dismantle the mould. A flanged end cover closes the nozzle and guarantees – in combination with the special geometry of the tip inserts – a friction-locked and leak-proof connection with the nozzle body.

By placing special sealing sleeves around the tips, a melt seal is realised directly at the gate. The nozzle body itself is not surrounded by melt. Together with streamlined flow channels inside the nozzle quick colour or material changes become possible.

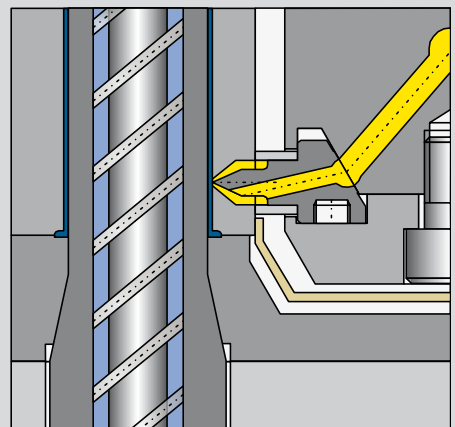

**Product features + Benefits**

- Direct gating with tip, no cold slugs, high gating point quality
- Available as linear or radial version as system nozzle or single tip
- Use with standard mould inserts
- Easy maintenance, tip inserts are exchangeable without the need to dismantle the mould
- Maximum processing temperature 300° C
- Maximum shot weight approx. 10 g per gate (low viscosity materials)

**Materials**

PE	PP	POM (CP)
ABS	PS	TPE

**HPS III-MH linear version**



Standard length: **60 mm**  
 (Distance nozzle seat – tip),  
 Total length variable by adapter

Possible number of gates: **4, 8**

Distance between cavities:  
 min **11** - max **48 mm**,  
 depending on number of gates

Distance between cavity rows:  
**55 mm - 60 mm**, variable by  
 length of tip insert

**HPS III-MH radial version**



Standard length: **60 mm**  
 (Distance nozzle seat – tip),  
 Total length variable by adapter

Pitch diameter:  
**53 mm - 58 mm**, variable by  
 length of tip insert

Possible number of gates:  
**2, 3, 4, 5, 6, 7, 8**

## HPS III-MH – Enhanced gating point options with angled tips

The special installation procedure for the tip inserts of the HPS III-MH nozzle does not only allow 90° gating but also to use tips with any required angle without needing to split the mould insert. This allows gating positions regarded impossible so far. Examples are 45° gating in chamfers or on angled surfaces as well as “vertical” side gating with a 0° angle in difficult-to-access areas such as flanges on cylindrical parts.

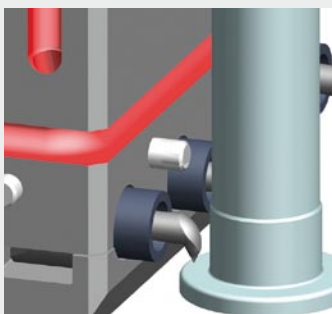

Tip insert for 0°  
 “vertical” side gating



Part with 0° gating point on  
 flange produced in an 8-drop  
 test mould

## New slim nozzle version for L2X Drop-In system

The L2X Drop-in system with screwed-in nozzles is completed by a slim nozzle version with a flow channel diameter of 4,5 mm. The new nozzle is available in lengths from 70 mm up to 180 mm. This makes it especially suitable for compact moulds and applications with gating points in hard-to-reach areas. The nozzle comes with torpedo tip or as valve gate version with pneumatic cooled drive units.

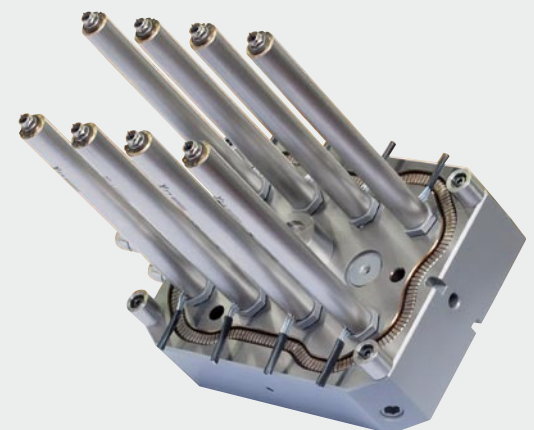



## Electric Valve Gate System in Steering Column Production at New-York Hamburger AG and Mercedes-Benz

**During the production of a damping element, an aluminum splined shaft is overmoulded with polyamide. The complexity of the insert requires a special valve gate solution for the hot runner system. An electric valve gate driven by a linear step motor moves to three different positions in one moulding cycle.**

A damping element currently being installed by Mercedes-Benz into the steering columns of the A-, B-, C- and E-Classes has an aluminum splined shaft which acts as part of a sliding seat. For vibration and noise damping purposes, the splined shaft is overmoulded in a 2-cavity mould with a layer of graphite-filled polyamide

4.6. The aluminum shaft contains two segments of support teeth spaced roughly 30 mm apart. They stabilize the teeth under torsional load. The PA component is injected into the recess between these segments. The polyamide layer forms the end contour along the entire length of the teeth, and is just 0.3 mm thick.

### Flawless parts required

As stipulated by Mercedes-Benz and the subcontractor New-York Hamburger AG, the overmoulded part has to meet the stringent requirements on surface quality and dimensions, since, in the following assembly step, it is fitted into its mate, which has internal teeth, and so must meet narrow tolerances. The logical solution to this challenge was to use a hot runner system employing valve gate technology. However, the complex teeth prevented the application from using conventional mould inserts or a slider mechanism. Instead, the insert part is placed in an un-split, wire-cut mould insert, where it is positioned and overmoulded. As the parts are demoulded at 90 degrees to the injection direction, it is essential that the valve pins be of precisely the same length. The designers had to rule out even the slightest elevation of the gate by a valve pin that was too short in view of the narrow dimensional tolerances imposed. Nor would it have been acceptable for a valve pin to project too far into the part as that would hamper

### About New-York Hamburger AG



Founded in 1871, the New-York Hamburger Gummi-Waaren Compagnie AG initially sold hard rubber products and extended its production in 1936 to include thermoplastic injection moulding parts. Today the company's core expertise lies in the selection, development, and processing of thermoplastics, elastomers, fiber composites and metal materials. Among other industries, the New-York Hamburger AG is a development partner and supplier to the automotive industry and manufactures both single- and multi-component

parts for vehicle interiors as well as metal-plastic hybrid parts for steering systems. A new manufacturing and administration building has been erected on a 30,000 sqm site in Lüneburg, Germany, and will open in early 2009.



the demoulding process. The EWIKON electric valve gate with linear step motor proved to be the ideal solution.

Unlike conventional pneumatic, hydraulic or electro-magnetic valve pin drives with fixed opening and closing positions for the needles, this system uses control software to incrementally adjust the valve pin end positions in 1/100 mm steps for both cavities separately and to change the positions as needed during the process. The hot runner components supplied include two valve pin drives, nozzles with a melt channel diameter of 6 mm and valve pin guides in the gate region, a straight two-cavity manifold with streamlined direction elements, including valve pin seal and guide, along with a console for operating the valve pin control.

### Three valve pin positions within one moulding cycle

Another advantage of the electric valve gate solution only came to light during the mould proving phase. Gating is effected directly on one of the tooth heads of the shaft. The useful width there is 0.8 mm. Preliminary tests soon showed that this gate diameter does not reliably ensure mould filling because of the small flow cross-sections and the fact that the aluminum insert is not preheated. This circumstance necessitated the use of a gate diameter of 1.2 mm. However, that would have produced a cylindrical bulge at the corresponding tooth flank in the finished mould part that, for the aforementioned

reasons of dimensional stability and demouldability, was unacceptable. The solution was to move the valve pin to three positions within one cycle – an option that could only be realized with a linear stepper motor in combination with the control software from EWIKON. After opening, injection and the holding phase, the valve pin does not move to the default position, but rather assumes an end position 0.5 mm below the tooth head. The tooth is 1.2 mm wide at that point. The advancing valve pin thus pushes the polymer filling the cylindrical bulge into the mould part. In the third step, it is retracted to the level of the tooth head – that is, the default position. The part can now be demoulded easily. The residual 0.5 mm deep cylindrical recess in the tooth does not impair the part properties.

### Valve Pins Networked to Mould Sensors and Machine Controller

The intelligent valve pin controller can be combined readily with other parts to optimize the process. The New-York Hamburger AG uses pressure sensors to measure the degree of mould filling. These control the duration of the holding pressure phase – as a function of the cavity pressure – and send the signal to close the valve pin to the controller – separately for each cavity. The controller waits until both valve pins have moved to their default position after the cooling phase before it sends a signal to the machine controller to initiate demoulding.

„Networking the valve pin controller to internal pressure sensors and machine controller gives us a high level of process safety,“ says Reno Heim, production head at New-York Hamburger AG. „The system also allows us to offset fluctuations in the viscosity of the material in the various batches, because we can use the controller to adjust the opening distance and opening time of the valve pins separately for each cavity.“



### „High process reliability“

Reno Heim, production head at New-York Hamburger AG, inspects the finished module

The automotive subcontractor produced the parts initially in its own factory. The overmoulded splined shafts were delivered just in time to the nearby Mercedes-Benz factory in Harburg, Germany. However, the planners had also made

continued on page 6

### The method (basic principle):

With the electric valve gate system, three valve pin positions are adopted within one cycle

Injection takes place in the recess between the support teeth packages. Only here is there enough space for the valve pins to advance

**Valve pin position 1:**  
Valve pin opens. Injection diameter is greater than the tooth head width. A cylindrical bulge forms in the tooth flank. Demoulding is not possible

**Valve pin position 2:**  
Valve pin moves below tooth head level and pushes the plastic in the bulge into the mould part

**Valve pin position 3:**  
Valve pin moves into default position at tooth head level. The part is demoulded at an angle of 90 degrees to the direction of injection

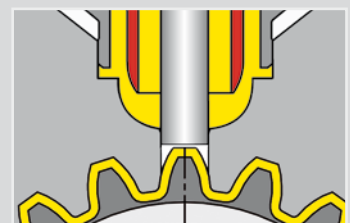
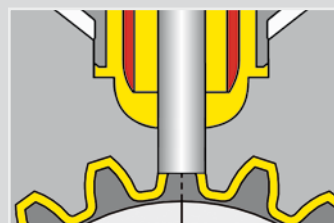
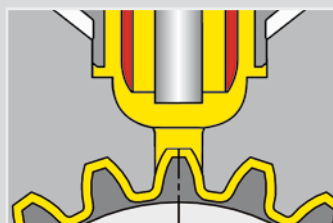
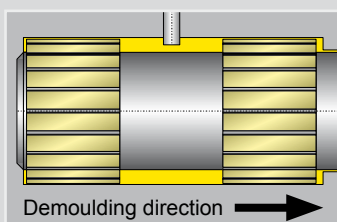

continued from page 5

provision for the possibility of a shop-in-shop solution, which finally saw the light of day in 2005. The injection moulding machine is now firmly integrated in the production line at Mercedes-Benz and is operated and maintained by eleven employees of the New-York Hamburger AG. After overmoulding, a handling system removes the splined shafts and places them on an assembly belt. A defined layer of lubricant is applied and an assembly robot then takes the parts and fits them into the internally toothed mate. Sensors check the axial and radial goodness of fit. If a pairing is outside the tolerances, the parts are separated and pairing is repeated with a new mate until the module meets the requirements.



The injection moulding machine operates as a shop-in-shop at Mercedes-Benz

The mould has been in operation for three years during which time it has produced 250,000 parts. However, the electrical valve gate solution has demonstrated its reliability and ease of use – an invaluable advantage when used in a production line.

#### Contact:

**New-York Hamburger Gummi-Waaren  
Compagnie AG**  
Nartenstraße 12  
21079 Hamburg / Germany  
Telefon: +49-(0)40-77 129-0  
Telefax: +49-(0)40-77 129-299  
e-mail: [info@nyhag.de](mailto:info@nyhag.de)  
[www.nyh.de](http://www.nyh.de)

## Flexible two-component nozzle for silicon cartridges, produced with spin stack mould and high-cavity hotrunner technology

**There has been a growing tendency in injection moulding processes to integrate functions into an article directly during production in order to reduce costs and to avoid subsequent working steps like assembly operations.**

**Company Rika Plast AS produces an in-house developed and patented two-component nozzle for silicon cartridges, the so-called “Rika Nozzle”. This nozzle enables craftsmen and do-it-yourselfers to work as time-effectively as possible in hard-to-reach areas. It has a centred swivel joint allowing for a continuous angular adjustment of the tip up to 90°. The rear part of the Rika Nozzle made of PP has a thread that is screwed onto the silicon cartridge, the rotatable front segment is made of PE.**

#### Patented mould technology

The Rika Nozzle is mass-produced on a high-cavity two-component injection moulding machine. One prerequisite was to eject the part fully operational in order to avoid additional working steps such as finishing or assembly operations. Therefore, it is necessary to bring the PP preform to a second moulding position in order to overmould it with the second

component. To prevent both components from bonding a certain cooling time between both working steps needed to be allowed for. Principally, it would have been possible to use a conventional rotary disc technology requiring a lot of space as well as complex machinery. However, a considerably more compact solution for this application was to use the patented “Spin Stack” technology of company Gram Technology where a rotatable centred block is used to change the position of the preform making a mould size of only 1146 x 616 mm for a 16 cavity mould possible.

The 16 inner mould cores are arranged vertically on the four surfaces of the centred block pivoting around its vertical axis in the parting line of the mould. The block is rotated 90° per injection cycle. Both components are gated in a 90° angle position to the opening direction of the mould, therefore both segments of the Rika Nozzle are side-gated.

There is a recess for the required cooling position in the contour plate of the hot half. After gating the PP component for the rear part of the Rika Nozzle the centred block turns into cooling position where the preform remains during one cycle. Then it turns into the second gating position where it is overmoulded with the PE component forming the tip segment. Turning again it reaches the ejecting position. The ejector mechanism of the machine activates a stripper plate located on the centred block which pulls the Rika Nozzle off its threaded seat on the mould core.

Clamps on the ejector side fix the article, so it can be pulled completely off the mould core and be ejected when the mould opens again.



View into the mould. Photo: Gram Technology



### 16-drop hotrunner inline – compact and naturally balanced

EWIKON supplied the complete 16+16-drop “hot half” with already integrated hotrunner system and complete wiring. As the recess for the cooling position needed to be left out, compact and straight manifolds with a length of 970 mm were required. These manifolds are fed by two machine units arranged in parallel, pitch distance is 57 mm. If high-

cavity manifold systems are arranged inline, perfect balancing is a prerequisite to achieve high process stability with even cavity filling.

As the material can be processed without any problems, the cost-efficient TE manifold technology could be used. This technology uses a combination of element and drilling technology in critical areas of the flow channel. Full natural balance of the system with a both horizontally and vertically very space-saving melt channel

layout on two levels is achieved by placing the direction elements accordingly.

The manifold width is only 128 mm, its height without sprue bush only 63 mm. Slim hotrunner nozzles with torpedo tip, a length of 129 mm and a melt channel diameter of 4.5 mm are used in front installation version and are, therefore, easily accessible for maintenance without the need to dismantle the system.

Each component has a shot weight of 2.5 g and a gating diameter of 0.8 mm, cycle time is 12 seconds.

The mould has been producing with no breakdowns and minimal maintenance efforts for both the hotrunner system and the spin stack technology since August 2007.

About 10 million “Rika Nozzles” have been produced so far.

#### Kontakt:

##### RIKA PLAST AS, Danmark:

Claus Jensen, Managing Director,  
Tel: +45 4975 0130

##### Gram Technology, Danmark:

Anders Johnsen, Director,  
Tel: +45 4582 4583

#### Functional principle:

Gating of the first component (1),  
Cooling position (2), Gating of the second component (3),  
Ejecting position (4)

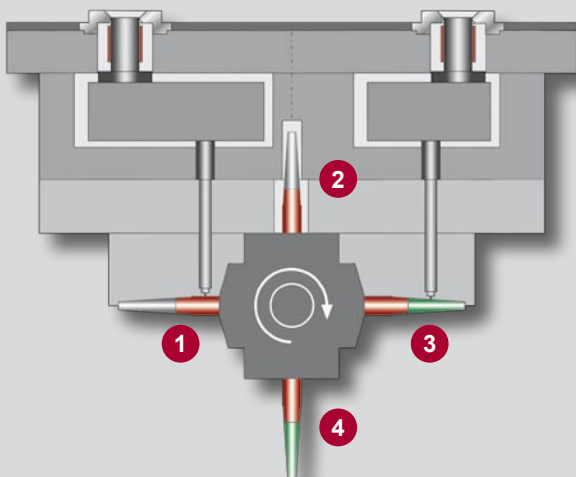

#### Flow channel layout of the manifold system:

By placing direction elements in areas of the flow channel where the melt stream is distributed it is easy to realise the demanded space-saving balancing on 2 levels

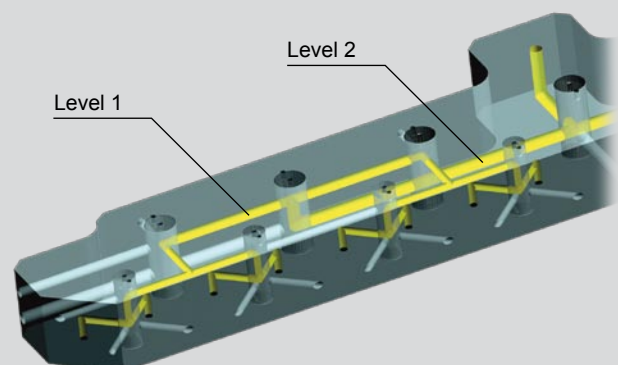

## Hotrunner systems for the medical industry – solutions for a growing market

When injection-moulding parts for the medical industry multi-cavity moulds and parts with highest quality are required in many cases. The EWIKON product range offers tailored hotrunner solutions for all demands of the medical industry. Included are standard systems for the economic large-scale production of medical disposables as well as compact multi-cavity valve gate systems for the moulding of high-precision parts with high process safety.

Today valve gating is the method of choice for many medical applications. It allows highest gating point quality with zero gate marks, avoids warping and in many cases reduces cycle times. The EWIKON range of valve gate systems offers multiple options regarding the position of the drive unit and the valve pin actuation. Multi-cavity systems with joint valve pin actuation are particularly interesting for medical applications. All valve pins are fixed in one actuator plate which is operated by one or more central drive units. This guarantees a precise simultaneous opening of all gates and an even filling of all cavities with high repeatability and low reject rate – especially important when moulding parts with small shot weights. As an additional advantage this technology allows a most compact mould layout. When used with slim hotrunner nozzles distances between gates as small as 12 mm are possible.



Compact hot half with valve gate system. Joint drive with all valve pins fixed in actuator plate

For most demanding applications EWIKON's electrical valve gate system with step motor technology proves to be the optimal solution in many cases. This clean drive version eliminates the risk of contamination by lubricated compressed air and therefore offers unlimited suitability for cleanroom applications. It allows a most precise control of the valve pin movement with individual adjustment of process parameters such as valve pin stroke length, valve pin speed and opening and closing time according to the application requirements.

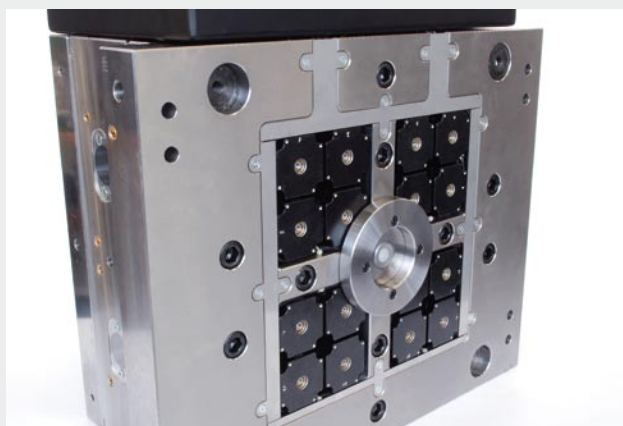

16-drop hot half with electric drive valve gate. The system does not only offer unique individual setup features but also facilitates mould construction. The drives can be arranged in simple cut-outs in a most compact layout

### EWIKON Heißkanalsysteme GmbH & Co. KG

Siegener Straße 35 • 35066 Frankenberg

Tel: (+49) 64 51 / 50 10 • Fax: (+49) 64 51 / 50 12 02

E-mail: [info@ewikon.com](mailto:info@ewikon.com) • [www.ewikon.com](http://www.ewikon.com)